

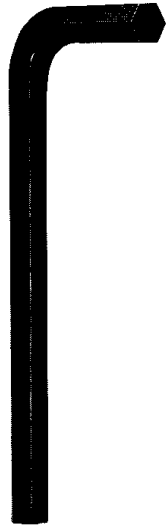

Alps socket screws

# Hex. Socket Screw Keys & Hex. Key Set

六角棒スパナと組六角棒スパナ Inch Series



## ■六角棒スパナの仕様

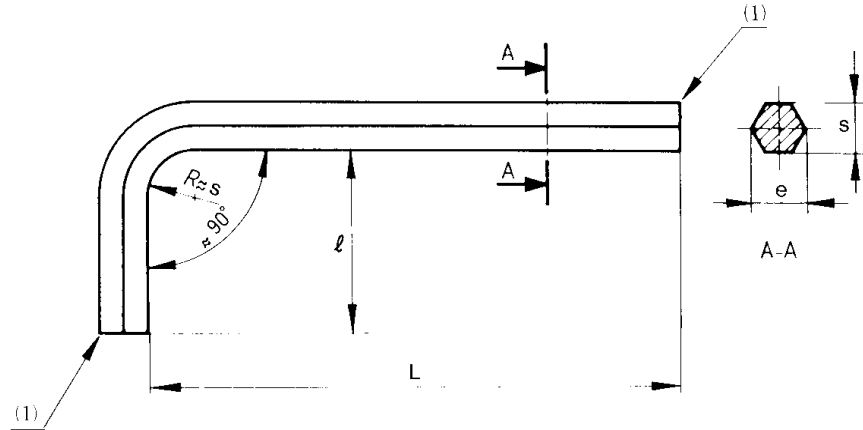

(単位mm)

呼び	S		l ±2.38	L ±2.38		硬 さ
	最大	最小		標準	長物	
1/16	1.587	1.563	14.27	44.45	76.20	HRC 45 ~ 53
5/64	1.983	1.959	15.46	47.62	80.97	
3/32	2.382	2.355	16.66	50.80	85.72	
7/64	2.778	2.736	17.85	56.26	90.47	
1/8	3.175	3.138	19.05	57.15	95.25	
9/64	3.571	3.543	20.21	60.32	100.58	
5/32	3.970	3.930	21.43	63.50	104.77	
3/16	4.762	4.725	23.82	69.85	114.30	
7/32	5.557	5.518	26.18	76.20	123.82	
1/4	6.350	6.300	28.57	82.55	133.35	
5/16	7.937	7.900	31.75	95.25	152.40	
3/8	9.525	9.475	34.92	107.95	171.45	
7/16	11.112	11.062	38.10	120.65	190.50	
1/2	12.700	12.637	41.27	133.35	209.55	
9/16	14.287	14.225	44.45	146.05	228.60	
5/8	15.875	15.812	47.62	158.75	247.65	

### 組六角棒スパナ

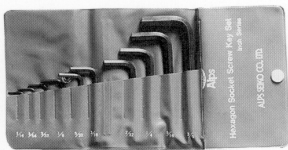

10本組

1/16, 5/64, 3/32, 1/8, 5/32, 3/16, 7/32, 1/4, 5/16, 3/8mm

### 仕様

材 質	合金鋼 : SAE8650, CRV2, SCM435
表面 処 理	黒色酸化被膜 + 防錆油

注 (1) 先端面取りなしとする。