



Alps socket screws

# Hex. Socket Screw Keys & Hex. Key Set

六角棒スパナと組六角棒スパナ

JIS B.4648-1988  
ISO 2936-1983

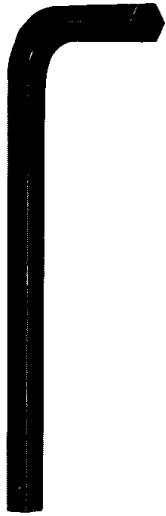

## ■六角棒スパナの仕様

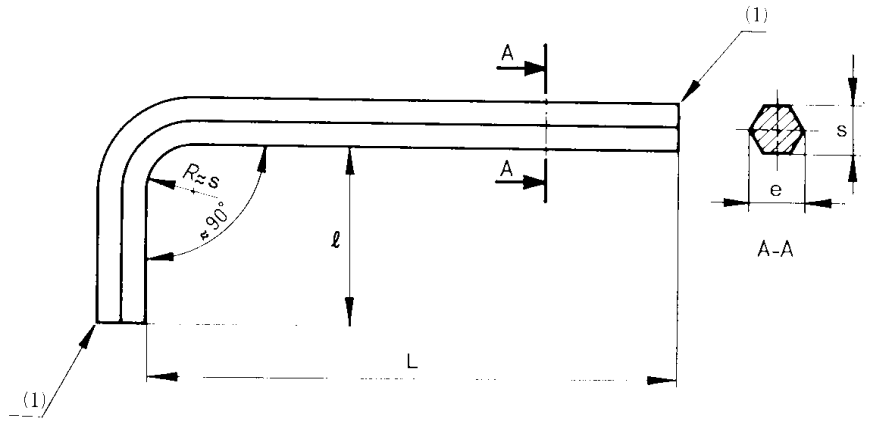

(単位mm)

形状及び寸法						機械的性質	
呼び	s 許容差	e 最小	L 約	l 約	R 約	硬 さ (最小)	保証トルク kgf・cm
1.5	0 -0.025	1.63	45	14	1.5		
2	0 -0.04	2.18	50	16	2	19.4	
2.5		2.75	56	18	2.5	38.7	
3	0 -0.048	3.31	63	20	3	67.3	
4		4.44	70	25	4	163	
5		5.58	80	28	5	306	
6	0 -0.058	6.71	90	32	6	530	
8		8.97	100	36	8	1224	
10	0 -0.11	11.23	112	40	10	HRC 48	2243
12		13.44	125	45	12		3773
14		15.70	140	56	14	6016	
17	0 -0.13	19.09	160	63	17	HRC 45	9993
19		21.32	180	70	19		13870
22		24.71	200	80	22		21520
24		26.97	224	90	24		28040
27	0 -0.16	30.36	250	100	27	HRC 45	39870
32		35.98	315	125	32		66380
36	40.50	355	140	36	94430		

### 組六角棒スパナ

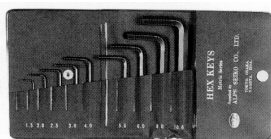

9本組  
1.5/2/2.5/3/4/5/6/8/10mm

### 仕様

材 質	合金鋼 : SAE8650, CRV2, SCM435
表面処理	黒色酸化被膜 + 防錆油

注 (1) 先端面取りなしとする。