



Alps socket screws

Hexagon Socket Set Screws

Unified Inch Series. Cup point

六角穴付き止めねじ くぼみ先

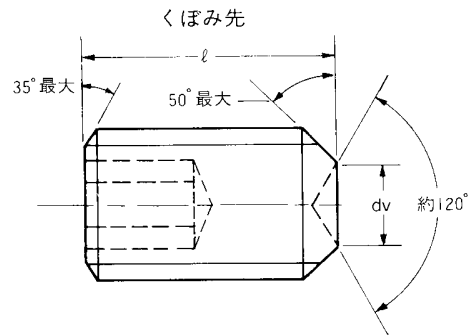
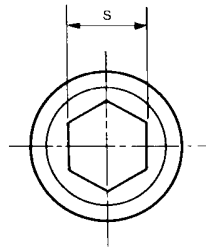

(インチ)

Dimensions 形状及び寸法						
Thread Size ねじの呼び	T.P.I. ねじ山数/インチ		Basic Screw Dia. ねじ外径	Cup Point くぼみ先		s (nom.) 呼び
	UNC	UNF		dv(max.) 最大	ℓ (min.pref.) 最小・推奨	
#0	-	80	.060	.033	3/32	.028
#1	64	72	.073	.040	1/8	.035
#2	56	64	.086	.047	1/8	.035
#3	48	56	.099	.054	5/32	.050
#4	40	48	.112	.061	5/32	.050
#5	40	44	.125	.067	5/32	1/16
#6	32	40	.138	.074	3/16	1/16
#8	32	36	.164	.087	3/16	5/64
#10	24	32	.190	.102	3/16	3/32
1/4	20	28	.250	.132	5/16	1/8
5/16	18	24	.312	.172	3/8	5/32
3/8	16	24	.375	.212	7/16	3/16
7/16	14	20	.437	.252	1/2	7/32
1/2	13	20	.500	.291	5/8	1/4



Alps socket screws

Hexagon Socket Set Screws

Unified Inch Series. Flat, Cone, Half Dog & Oval Points

六角穴付き止めねじ 平先、とがり先、半棒先、丸先

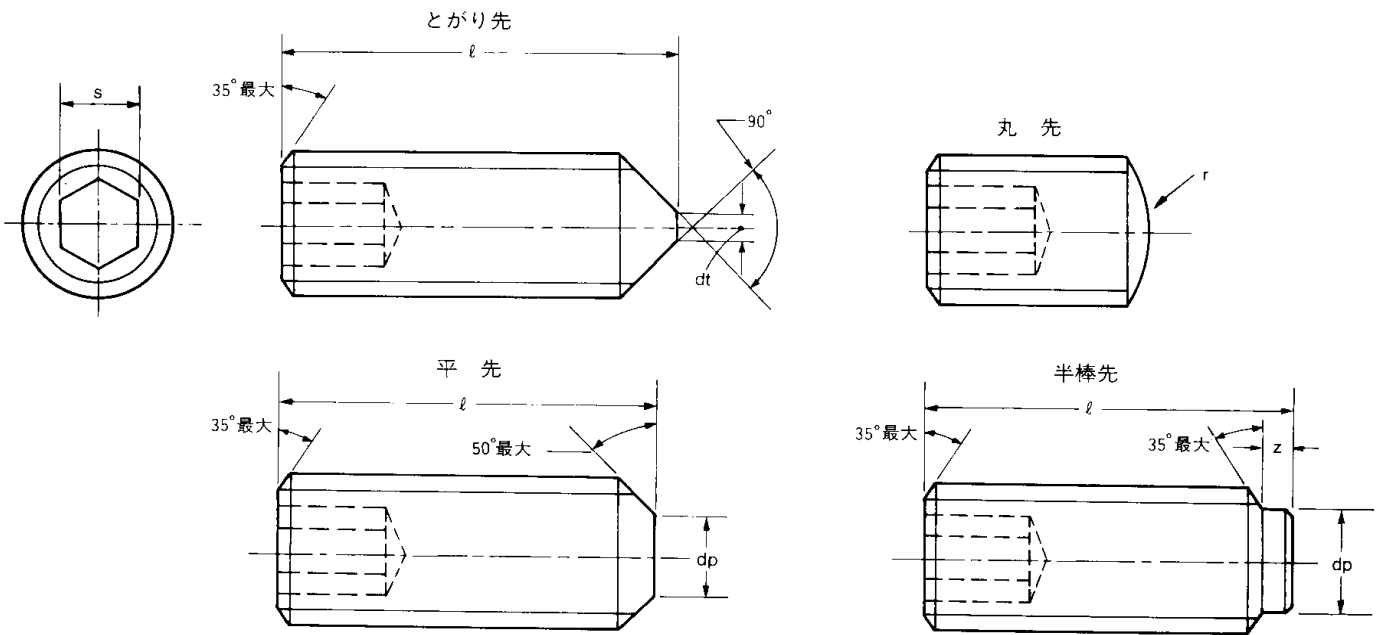

(インチ)

Dimensions 形状及び寸法									
Thread Size ねじの呼び	T.P.I. ねじ山数/インチ		Basic Screw Dia. ねじ外径	Flat Point 平先 dp(max.) 最大	Cone Point とがり先 dt	ℓ (min.pref.) 最小・推奨	Half Dog Point 半棒先		Oval Point 丸先 r(rad.)
	UNC	UNF					dp(max.) 最大	z(max.) 最大	
#0	-	80	.060	.033	sharp	3/32	.040	.017	.047
#1	64	72	.073	.040	sharp	1/8	.049	.021	.055
#2	56	64	.086	.047	sharp	1/8	.057	.024	.062
#3	48	56	.099	.054	sharp	5/32	.066	.027	.073
#4	40	48	.112	.061	sharp	5/32	.075	.030	.084
#5	40	44	.125	.067	sharp	5/32	.083	.033	.092
#6	32	40	.138	.074	sharp	3/16	.092	.038	.109
#8	32	36	.164	.087	sharp	3/16	.109	.043	.125
#10	24	32	.190	.102	sharp	3/16	.127	.049	.141
1/4	20	28	.250	.132	sharp	5/16	.156	.067	.188
5/16	18	24	.312	.178	sharp	3/8	.203	.082	.234
3/8	16	24	.375	.212	sharp	7/16	.250	.099	.281
7/16	14	20	.437	.252	sharp	1/2	.296	.114	.328
1/2	13	20	.500	.291	sharp	5/8	.318	.130	.375

仕様

強度区分	45H	A2-70
材質	合金鋼	XM-7
硬さ	HRC 45-53	-
ねじ精度	3A	2A
部品等級	A	A
表面処理	黒色酸化被膜 +防錆油	光沢処理